

# TapNLink TnL-FIT203 (NFC) Datasheet

22 September 2020  
Version 1.2



## Contents

1	Introduction .....	3
2	Summary .....	4
3	Block schematic.....	5
4	Development environment.....	6
4.1	TapNLink module configuration .....	6
4.2	Mobile device software .....	6
5	Features.....	7
5.1	Communication channels .....	7
5.1.1	Near Field Communication (NFC) .....	7
5.2	Target system interface .....	7
5.3	Security features.....	8
5.3.1	Access control configuration.....	8
5.4	Electrical characteristics .....	8
5.4.1	Power supply .....	8
5.4.2	Digital levels.....	8
5.5	Mobile device support.....	8
5.6	Operating temperature range .....	8
6	Pin assignment .....	9
6.1	J1 pinout .....	9
6.2	J3 pinout .....	10
6.3	P1 extension connector .....	10
7	Regulatory compliance .....	11
7.1	CE certification (Europe) .....	11
8	Mechanical characteristics .....	12
8.1	Module dimensions .....	12
8.2	Standard plastic case .....	12
8.3	Ordering Codes and Options .....	13
9	EU Declaration of Conformity (DoC) .....	14
10	History.....	16



## 1 Introduction

**IoTize™** offers a complete solution for instant integration of wireless connectivity that links electronics to mobile devices and the Cloud. This solution is inspired by the advantages of adding network connectivity without redesigning existing systems or recoding their firmware. It supports integrators with software and features for instant creation of customized Human Machine Interfaces (HMI) that run on mobile devices, configurable access control, security and Cloud integration.

The **TapNLink™** line uses technologies and techniques that are typically reserved for system programming and debugging to connect directly the target system's microcontroller. This unique approach makes it possible to add connectivity without redesigning the system. It speeds integration, eliminates risks and delivers design flexibility through encapsulation of complex wireless communication, network and security technologies. This facilitates the initial integration, but also makes it possible to easily evolve the wireless connection to meet future needs or technology evolutions... and still without ever recoding the system's original software.

TapNLink provides fully qualified wireless implementations. These allow local connection to mobile devices (smartphones, PDAs, tablets, PCs, etc.) allowing users to monitor or update a system and transfer data to the Cloud if/when necessary. Depending on the connectivity channels on the module, TapNLink can also enable connection to WAN or LPWAN for remote supervision and remote access control from the Cloud.

For the embedded application, TapNLink enables:

- Mobile device-based HMI.
- Data transfer to the internet.

TapNLink provides software and hardware encapsulation of the mobile device / target application communication. It manages communication with:

- Target application via hardware module RF interface(s) and communication co-processor.
- Mobile devices via a low-level service application.

## 2 Summary

The TapNLink NFC module (Part N°: TnL-FIT203) offers instant integration of a contactless communication interface to enable the connection of a microcontroller-based target system to a local information appliance (smartphones, PDAs, tablets, PCs, etc.).

TapNLink connects directly the microcontroller of the target system and allows non-intrusive read and/or write access to variables in the target microcontroller's memory. The data addresses and access parameters for the target system are configured in the TapNLink. No coding of the target system's native functionality is required to connect TapNLink to the target microcontroller.

TapNLink supports local connection to mobile devices (Android or iOS), where data can be viewed and modified via a graphical user interface created by the target system designer.

### Communication Channels

- Near Field Communication (NFC) Type5 tag (ISO/IEC 15693)

### Target system interface protocols

- SWD debugging/programming interface protocol
- Software Secure Serial Port (S3P)
- UART (Modbus based) protocol

### Security features

- Configurable access profiles
- Configurable, encrypted passwords
- AES-128 module-level data encryption

### Configurable target memory access controls

- Accessible data addresses: up to ~ 500
- User profiles: up to ~ 100
- Access capabilities: Read or Write or Read/Write

### Electrical characteristics

- Input voltage: 2.3V to 3.6V
- Low power consumption:

	Typical	Energy harvesting mode
Standby:	1 $\mu$ A	0
Tx/Rx	1 mA	0

### Mechanical characteristics

- Dimensions: 28 x 38 x 3 mm

### Package options

- Bare board
- Plastic casing (IP44)
- Silicone resin (IP65)

### Operating temperature range

- -20°C, +55°C

### Acceptance

- CE (Europe)
- REACH and RoHS compliant

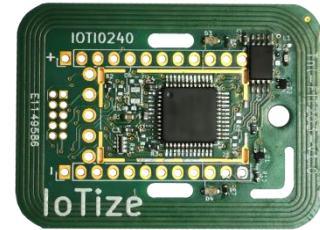

### 3 Block schematic

The TapNLink NFC module is equipped with an STM32 microcontroller that executes:

1. The main program
2. Manages the upper level protocols
3. Manages the configuration and access control.

The NFC antenna is a trace at the periphery of the printed circuit board.

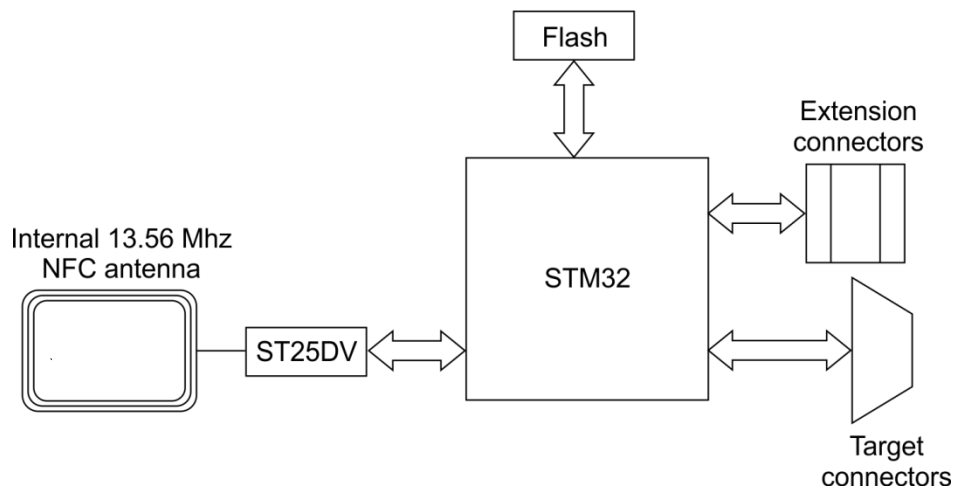



## 4 Development environment

### 4.1 TapNLink module configuration

TapNLink is implemented by configuration only using the free IoTize Studio software environment, which is available on the IoTize website.

IoTize Studio provides a simple yet complete interface for configuring IoTize radio modules so that they interface correctly with the target system. IoTize Studio provides:

- Drag-and-drop configuration of target data addresses using the target system's source code (ELF files)
- Instant configuration transfer without extensive hardware installations
- Immediate configuration verification on the designer's PC and mobile device

When creating the TapNLink configuration, the designer imports the target system's firmware source (ELF file). Designating the addresses to access via TapNLink is as easy as dragging-and-dropping them into the configuration project. All variable information (address, type, etc.) is copied directly from the firmware source file, greatly reducing the risk of configuration errors. IoTize Studio also notifies the designer if the firmware source file is modified after the configuration has been created.

IoTize Studio allows users to transfer their configuration for testing and deployment with just the click of a button. No complicated or expensive hardware is required.

After configuration, the designer can connect to the module and visualize in IoTize Studio the results of the configuration. The integrated app viewer in IoTize Studio shows the resulting user app exactly as it would display on a mobile device. When the designer is satisfied with the configuration, visualizing the result on a mobile device requires only that the designer connect it to the TapNLink via one of the supported radio interfaces.

IoTize Studio and TapNLink are designed to allow the transfer of the Designer's configuration using a direct NFC connection with the designers PC, or via a mobile device connection either directly with the designer's PC or IoTize's Cloud-based MQTT relay. Thanks to this implementation no additional hardware is required during the design phase.

### 4.2 Mobile device software

Various documents are available on the IoTize website that describe how to design HTML pages to monitor the TapNlink from a mobile device. APIs for native programs are also available.



## 5 Features

The TapNLink NFC module offers instant integration of a contactless communication interface to enable the connection of a microcontroller-based target system to a local mobile device (smartphone, PDA, tablet, PC, etc.).

TapNLink connects directly to two GPIOs on the microcontroller in the target system. These GPIOs can be either the target microcontroller's debugging/programming port (ex. SWD) or any pair of GPIOs enabled by the IoTize S3P protocol (application relinking is required). The connection to the target microcontroller is non-intrusive and allows read and/or write access to variables in the target microcontroller's memory. The data addresses and access parameters for the target system are configured in the TapNLink using the IoTize Studio configuration environment.

TapNLink communicates with local mobile devices via their NFC interfaces. The Tap Manager app (Android or iOS) on the mobile device manages the mobile's NFC interface, thus eliminating the need for the target-system designers to code or validate this. Designers instead focus on creating the user interface for the target system.

With TapNLink NFC modules, a local mobile device can also serve as a network gateway to bring data to or retrieve data from the Cloud. Data that is read by the TapNLink can be transmitted via the mobile device's data or network connection when available. For this, IoTize provides an MQTT-based relay with IoT Cloud platform translators. This MQTT infrastructure is open source software that designers can install on servers and adapt to any private or public IoT Cloud platform.

### 5.1 Communication channels

#### 5.1.1 Near Field Communication (NFC)

- Data transmission rate<sup>1</sup>: 2 kilobytes per second
- Range<sup>2</sup>: to 4 centimeters
- Supports use of NFC in energy harvesting mode – all energy required by the module is provided by the mobile device during the NFC connection.

### 5.2 Target system interface

Requires 2 GPIO enabled by the target microcontroller's debug protocol or IoTize Simulated Secure Serial Port (S3P).

### 5.3 Security features

Customized firmware allows differentiated algorithms for each application. The communication chain is fully secured using classic techniques such as:

- Authentication: secured passwords or signed tokens
- Encryption: AES-128

When implementing on GPIO that are enabled by the target microcontroller's debug protocol, data encryption is enabled to the level of the TapNLink module.

When implementing with S3P protocol, security features can be implemented on the target microcontroller. Features include data encryption and filtering of accessible addresses in the target's memory space.

#### 5.3.1 Access control configuration

IoTize stores access control data in 2KB of E<sup>2</sup>PROM:

- Accessible data addresses: up to ~ 500
- User profiles: up to ~ 100
- Access rights: Read/Write
- Plus 3 predefined profiles of up to 96 characters.

### 5.4 Electrical characteristics

#### 5.4.1 Power supply

- Maximum DC supply voltage 3.6V
- DC supply voltage 2.3V to 3.6V
- Low power consumption:

	Typical	Energy harvesting mode
Standby:	1 $\mu$ A	0
Tx/Rx	1 mA	0

Supports use of NFC in energy harvesting mode – all energy required by the module is provided by the mobile device during the NFC connection. Harvested energy (up to 3 mA) can be relayed to power devices in the target application.

#### 5.4.2 Digital levels

- Maximum voltage on input/output:  $V_{cc} + 0.3V$
- Minimum voltage on input/output: 0.3V
- Input low voltage (max):  $0.25 \times V_{cc}$
- Input high voltage (min):  $0.75 \times V_{cc}$

### 5.5 Mobile device support

TapNLink includes radio implementations for NFC which is compatible with a wide range of mobile devices running Android or iOS operating systems.

The Tap Manager app manages the NFC interface on mobile devices running Android v4.0.3 and iOS v13 or later versions.

### 5.6 Operating temperature range

The behavior and the radio characteristics have been tested to guarantee a correct operation in the range [-20°C, +55°C].



## 6 Pin assignment

The TapNLink NFC module has 3 connectors:

- J1 (2x5 in 1.27mm steps) which connects the TapNLink to the debug connector (ARM-SWD standard) of the target board via a flex cable (in 0.635mm steps).
- J3 (1x5 in 2.54mm steps) which connects the TapNLink to the target board using free wires that need not be grouped in a ribbon cable or with a single end connector. Note that J3 is a subset of J1.
- P1 extension connector which is composed of two rows of contacts (P1A and P1B) with 2mm spacing. This connector is mainly reserved for the addition of expansion cards and is only briefly described in this document.

The following figure shows (bottom view) the signals connected to J1 and J3:

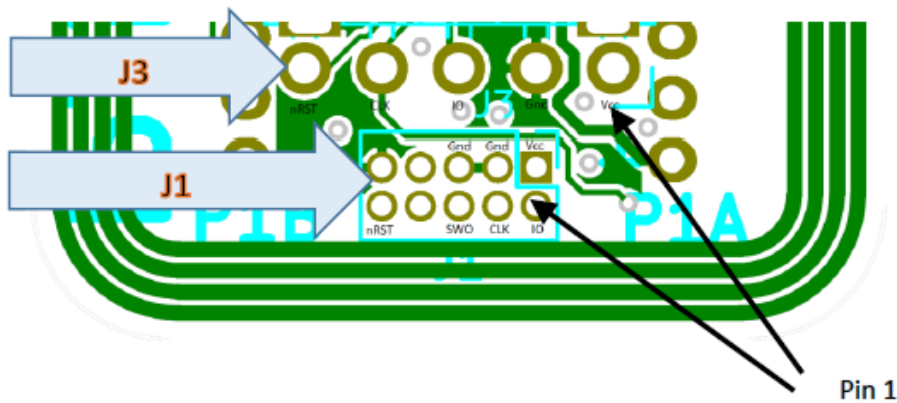

### 6.1 J1 pinout

This connection corresponds to the format specified by ARM for Cortex-M microcontrollers

Vcc	1	•	•	2	S3PIO/SWDIO (TMS)
Gnd	3	•	•	4	S3PCLK/SWDCLK (TCK)
Gnd	5	•	•	6	SWO (TDO)
Not connected	7	•	•	8	-- (TDI)
Gnd	9	•	•	10	nRST

**Note:**

The names in parentheses correspond to the JTAG protocol. In general, it is advisable to favor SWD over JTAG for Cortex M-based microcontrollers. For any other microcontroller, use the S3P protocol.

The signals to be connected in SWD or S3P are:

- Gnd
- Vcc (the target must provide the TapNLink power),
- S3PIO/SWDIO, a bi-directional data signal.
- S3PCLK/SWDCLK, the clock signal, bi-directional in S3P.
- NRST: Reset signal of the target processor. Its connection is optional. It should be maintained if you want to use the reset command, or if you want to use TapNLink as a programmer (the reset signal is required in some programming situations).

## 6.2 J3 pinout

J3 was added for practical reasons. The 2.54 mm step connectors are cheaper and more robust and can connect to a wide range of other connectors. It is easier to use this connector to connect to the 20-point ARM 2.54mm-step standard.

J3 does not correspond to a standard. It contains the signals necessary for S3P and SWD protocols:

Vcc	1	●
Gnd	2	●
S3PIO/SWDIO	3	●
S3PCK/SWDCK	4	●
nRST	5	●

## 6.3 P1 extension connector

P1 extension connector is composed of two mechanically independent parts:

- P1A has 8 points
- P1B has 8 + 2 = 10 points. The two additional points are used exclusively for initial programming.

Most of the signals on the expansion connector are reserved for extensions proposed by IoTize, so this connector will only be used in exceptional situations, for example, if it is necessary to control the reset of the TAP, or use UART (P1B.7: TxUART, P1B.8: RxUART).

The figure below shows the position of the TapNLink's power, reset and wakeup points.

GND/P1A.12	●	●	P1B.12 /Vcc
P1A.11	●	●	P1B.11
P1A.10	●	●	P1B.10
P1A.9	●	●	P1B.9
P1A.8	●	●	P1B.8 / RxUART
P1A.7	●	●	P1B.7 / TxUART
P1A.6	●	●	P1B.6
Tap_nRST / P1A.5	●	●	P1B.5
P1A.4	●	●	P1B.4
P1A.3	●	●	P1B.3 / Tap_Wakeup
P1A.2	●	●	P1B.2
Vcc / P1A.1	●	●	P1B.1 / GND



## **7 Regulatory compliance**

The TnL-FIT203 is a Near Field Communication (NFC) tag or “passive device,” and does not emit its own advertising signal. For this reason, certification under FCC, IC and CE-RED regulations is not required.

Changes or modifications not expressly approved by IOTIZE S.A.S. could void the user’s authority to operate the equipment.

This TapNLink is tested and qualified under the following standards:

### **7.1 CE certification (Europe)**

This device has been tested and certified for use in the European Union and IOTIZE hereby declares that the device “TapNLink TnL-FIT20x” is in conformity with the essential requirements EU directives for electronic parts and assemblies.

If this device is used in a product, the OEM is responsible for verifying compliance of the final product with the relevant EU standards. A Declaration of Conformity must be issued and kept on file. The ‘CE’ mark must be placed on the OEM product per the labeling requirements of the Directive.

## 8 Mechanical characteristics

### 8.1 Module dimensions

The main dimensions are noted in the diagram below (bottom view):

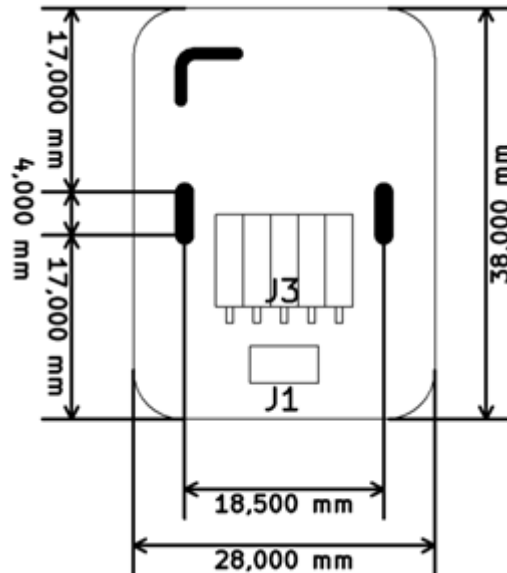

Dimensions<sup>3</sup>: 28 x 38 x 3 mm

Weight: 3 g

### 8.2 Standard plastic case

An optional plastic casing is available from IoTize (see dimensions below):

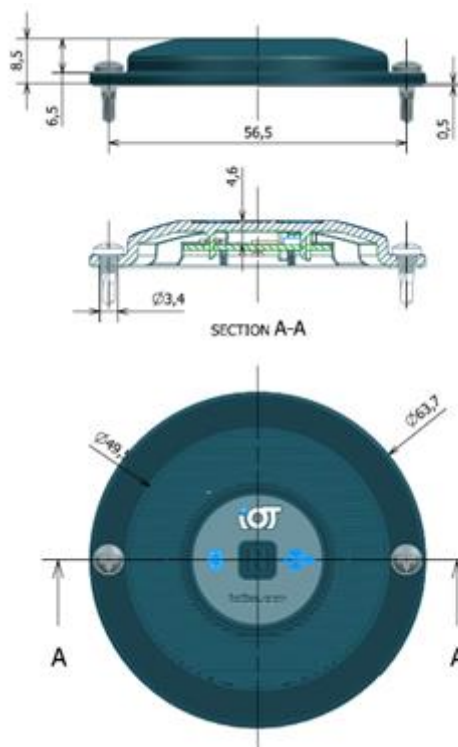

### 8.3 Ordering Codes and Options

Base part number: **TnL-FIT20x**

Available part numbers:

- TnL-FIT203

Product Line	Use Mode	Physical Interface	Radio Interface <sup>1</sup>	Product Prefix	Security	Casing Type	Power Supply
<b>TnL</b>	<b>F</b>	<b>I</b>	<b>T</b>	<b>10</b>	<b>3</b>	<b>-0</b>	<b>-TO</b>

<b>Product Lines:</b>	<b>TnL = TapNLink<sup>1</sup></b>
<b>Use Mode:</b>	<b>F = Fixed</b> (powered by target system)
<b>Physical interface:</b>	<b>I = SWD/S3P/UART</b>
<b>Radio interface:</b>	W = Wi-Fi, <b>T = NFC Only</b> , R = BLE, B = Bluetooth Classic, L = BLE, LoRa
<b>Security:</b>	<b>3 = Software based</b>
<b>Casing Type<sup>2</sup>:</b>	<b>-0 = No casing option selected</b>
<b>Power Supply:</b>	<b>-TO = Powered by target system only</b>

Notes:

1. The features of the part number shown in the table are indicated in bold.
2. The ABS plastic casing is available as an option with its specific type number.

## 9 EU Declaration of Conformity (DoC)

### EU Declaration of Conformity (DoC)



**We, the undersigned:** IoTize S.A.S.  
 960, Chemin de la Croix Verte  
 38330 Montbonnot St Martin  
 France  
 Email: [contact@iotize.com](mailto:contact@iotize.com)  
 Phone : +33 4 76 41 87 99

**Designated product:** TapNLink NFC Low Energy module

Model: TnL-FIT20x  
 Frequency band 1: 13,56 MHz

**Certify and declare:** **under our sole responsibility that the designated product is in conformity with the essential requirements and provisions of the following European Directives:**

Directive 2014/53/EU of the European Parliament and of the Council of 16 April 2014 on the harmonisation of the laws of the Member States relating to the making available on the market of radio equipment (RED).  
*The conformity of the designated product(s) with the provisions of this European Directive is given by the compliance with the following European Standard(s):*

Essential requirements of article 3.1a) of RED: (Safety, electrical)	- EN 62368-1 (2014)
Essential requirements of article 3.1a) of RED: (Safety, health)	- EN 62311 (2008)
Essential requirements of article 3.1b) of RED: (Electromagnetic Compatibility)	- ETSI 301 489-1 (V2.1.1) - ETSI 301 489-3 (V2.1.1)
Essential requirements of article 3.2) of RED: (Efficient use of radio spectrum)	- ETSI EN 300 330 (V2.1.1)

Directive 2011/65/EU of the European Parliament and of the Council of 8 June 2011 on the restriction of the use of certain hazardous substances (ROHS) in electrical and electronic equipment.

Directive 2012/19/EU of the European Parliament and of the Council of 4 July 2012 on waste electrical and electronic equipment (WEEE).



## EU Declaration of Conformity (DoC)



<b>Important Notice:</b>	Red approval is only valid for products in delivery state, including standard hardware and software. The user is responsible for operating the radio equipment and the accessories as intended and in accordance with the provided instructions. It is the responsibility of the OEM manufacturer to demonstrate compliance with all applicable EU directives and standards. The IoTize declaration of conformity serves as a support input for the declaration of conformity for the final equipment.
--------------------------	--

**The technical construction file is available from:**

IoTize S.A.S  
960 Chemin de la croix verte  
38330 Montbonnot Saint Martin  
Phone: +33 4 76 41 87 99

*Issued on September 22<sup>nd</sup>, 2020.*

**Name and position of person binding the manufacturer or his authorized representative:**

Name: Francis Lamotte  
Position: President  
Email: [francis.lamotte@iotize.com](mailto:francis.lamotte@iotize.com)

Signature:



## 10 History

Date	Version	Author	Modification
June 12 <sup>th</sup> 2020	1.0	FL	First draft version.
July 13 <sup>th</sup> 2020	1.1	JH	Updated P1 UART pins.
Sept 22 <sup>nd</sup> 2020	1.2	JH	TnLFIT103 -> TnLFIT203

### Disclaimer

Information in this document is subject to change without notice and does not represent a commitment on the part of the author(s).

No part of this document may be reproduced or transmitted in any form or by any means, electronic or mechanical, including photocopying, recording, or information storage and retrieval systems, for any purpose other than the development of the IoTize™ technology, without prior written permission from IoTize SAS and the IoTize™ consortium members.

Every effort has been made to ensure the accuracy of this manual and to give appropriate credit to persons, companies and trademarks referenced herein.

This document exists in electronic form (pdf) only.

### Copyright © IoTize All rights reserved

*IoTize™ is a registered trademark of IoTize SAS. All other registered names and trademarks are the property of their respective owners.*